



Installation Instructions

PrintFrame™
Graphic Frames
1-3/8" – Double-Sided

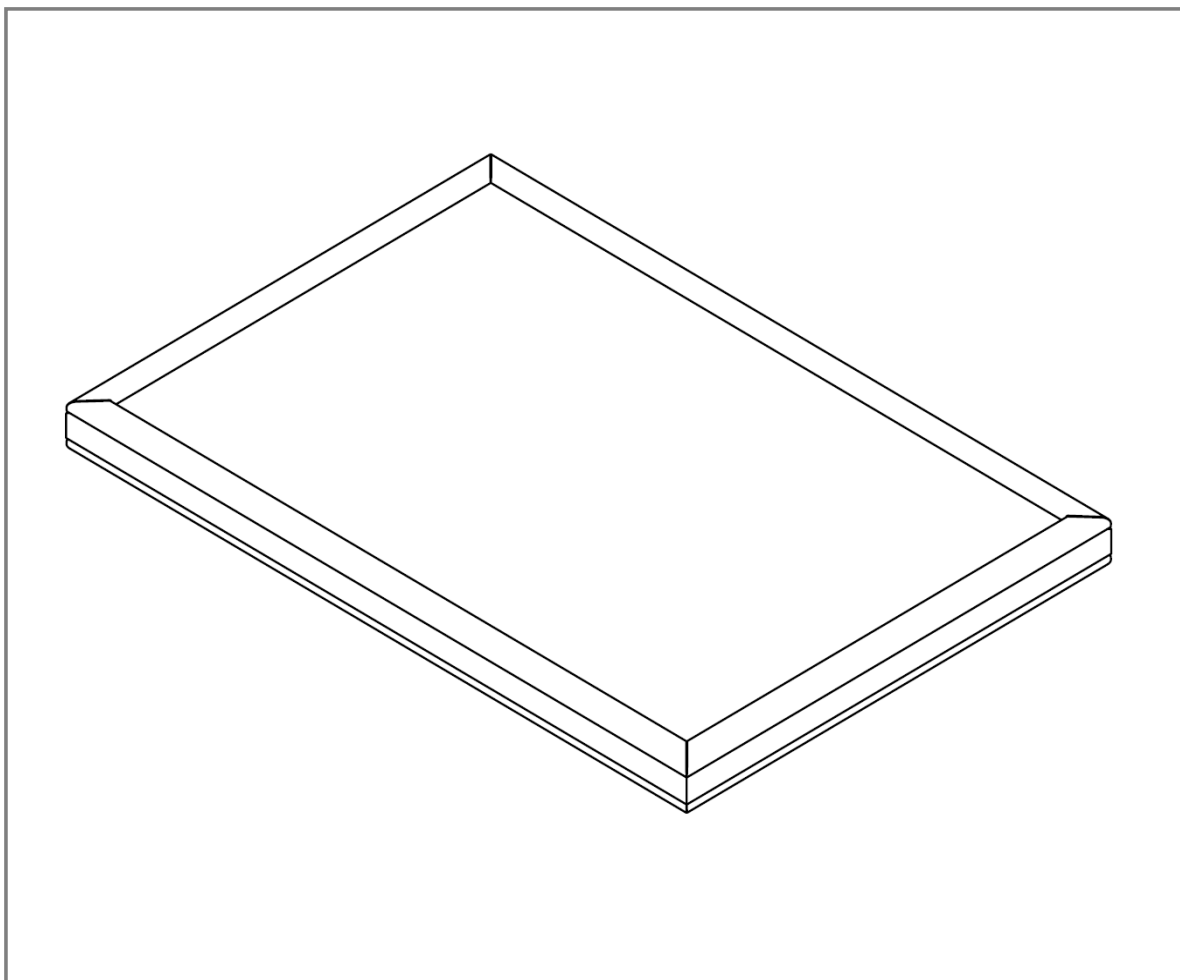

Figure 1

INSTALLATION INSTRUCTIONS

Before you begin

These instructions illustrate the Stylmark® PrintFrame™ 1-3/8" Double-Sided Graphic Frames. If you have questions during assembly, call 800-328-2495 to request technical assistance.

Tools you'll need

- Screwdriver

Please read these instructions carefully before beginning installation.

Part Number# 971696
Rev A (9/11)

Stylmark Installation Instructions: PrintFrame™ - 1 3/8" Double-Sided

Step-by-Step Instructions – Graphic Installation:

1. Open the frame by flipping back all four sides of the frame. **See Figure 2.**
2. Place the graphic in the print frame.
3. Close frame on all sides.

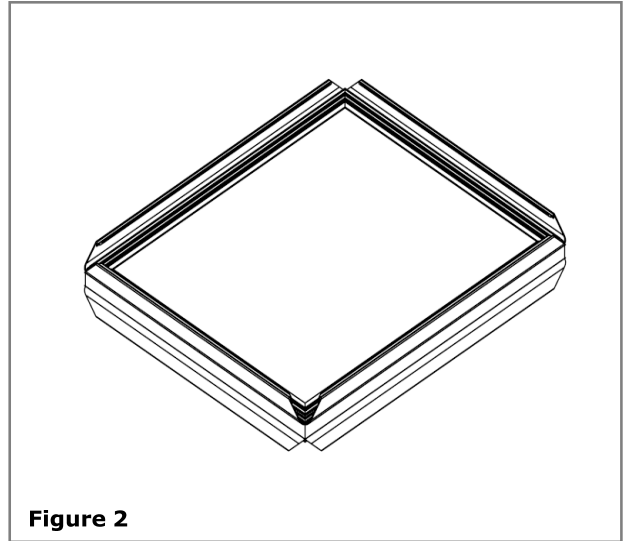

Step-by-Step Instructions – Pedestal Mount Options

Note: This option should be requested at time of order.

1. Attach the pedestal feet to the posts using the socket head screws and Allen wrench provided. **See Figure 3.**

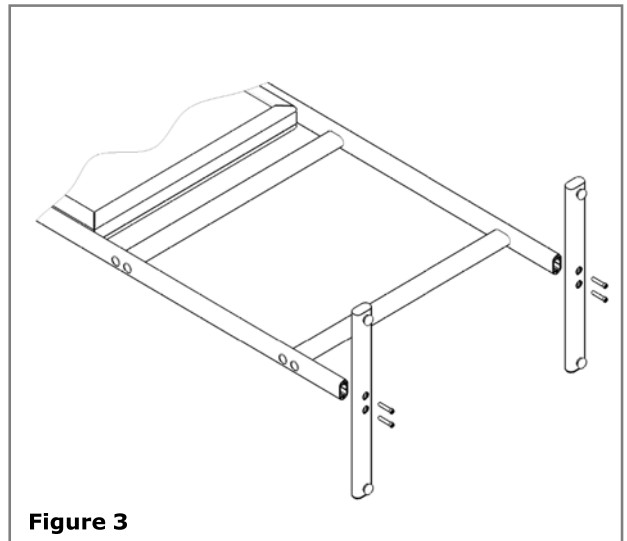

Step-by-Step Instructions – Table Top Option:

Note: This option should be requested at time of order.

1. Attach feet to print frame using the screws & spacers provided. **See Figure 4.**

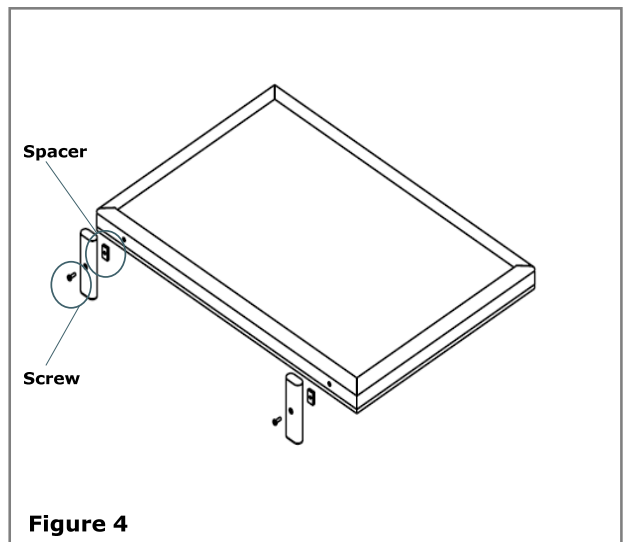

Part Number# 971696
Rev A (9/11)

Stylmark Installation Instructions: PrintFrame™ - 1 3/8" Double-Sided

Step-by-Step Instructions –Suspended Mounting Option

Note: This option should be requested at time of order.

1. Hanging loops are attached to the unit when constructed. Attach appropriate hanging hardware (chain, cables, etc.) to suspend unit. **See Figure 5.**

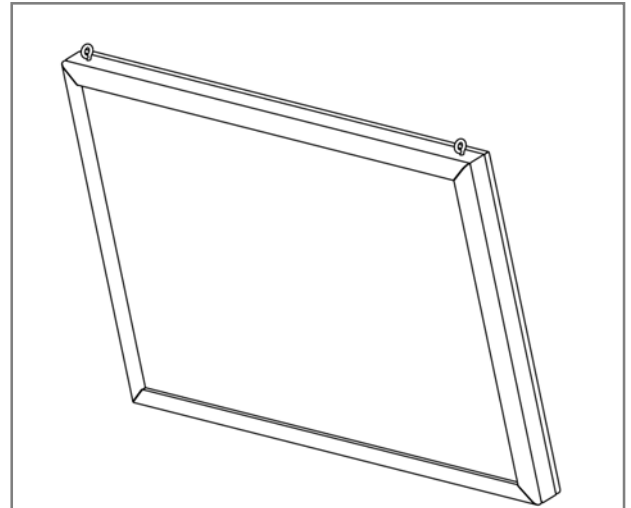

Figure 5

Step-by-Step Instructions – Corner Alignment:

If the frames have migrated during shipping and look similar to the “before” picture in figure 7, follow these steps to correct the alignment. .

1. Open back all four sides of the frame. **See Figure 2.**
2. Wiggle one frame section opening and closing as you slide the edge of the frame to match up with the edge of the sign body extrusion. **See Figure 6.**
3. Close the frame and proceed to an adjoining frame section until all four sections are closed and the corners match up. **See Figure 7.**



Figure 6

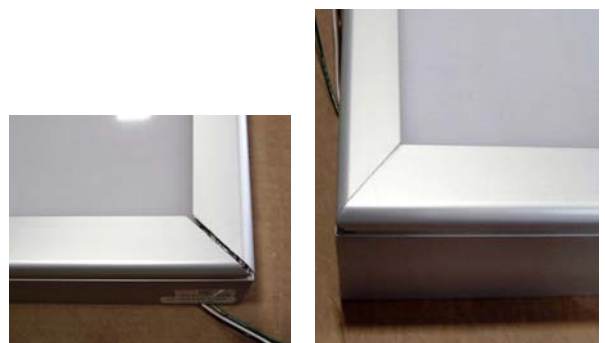

Figure 7

Part Number# 971696
Rev A (9/11)