

# Rolling Doors

Fully framed security rolling doors are a standard component of the Stylmark aluminum showcase system. Our industry leading doors feature anti-jump security rolling hardware, which engages the door bottom to the flanges on the track. This retainer also prohibits removal of the door while it is locked. Stylmark rolling door hardware and components are available in 12' stock lengths, or may be custom fabricated to your specified lengths and requirements.

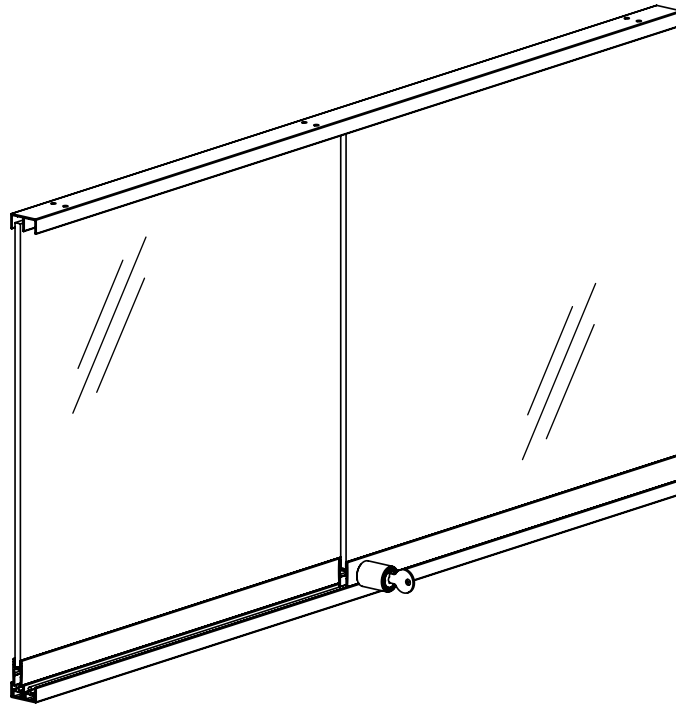

ORDERING ROLLING DOORS	
MODEL #	REFER TO PAGES 44 - 56 OF THIS BROCHURE
NUMBER OF DOOR PANELS	FOR ASSEMBLIES OVER 63" WIDE, FOUR DOORS WITH A CENTER MULLION ARE RECOMMENDED.
LOCK CONDITION	KENSTAN, PLUNGER LOCK OR FABRICATED FOR BEST LOCK
OPENING SIZE	WIDTH x HEIGHT (DOOR VERTICALS ARE REQUIRED ON DOORS OVER 36" IN HEIGHT)

**Notes:**

- When ordering rolling door hardware for clipped or curved showcases, please provide shop drawings.
- Rolling door cabinet hardware can be ordered in stock length material for customer fabrication.
- Lock and vinyl are sold separately when 12' assemblies are ordered.
- Door verticals are required on doors over 36" high.

# Rolling Doors

## Model Components

ROLLING DOOR MODEL #	COMPONENT PIECES						
	TOP CHANNEL	DOOR TOP	DOOR BOTTOM	WHEELS & RETAINERS	BOTTOM TRACK	JAMB	DOOR VERTICALS
610005	110007	419007	110012	510001	110007 110009	OPTIONAL	N/A
610007	110007	419007	110012	510001	110019	OPTIONAL	N/A
610060	110080	N/A	N/A	510041	110079	N/A	N/A
610099	110007	419007	110012	510001	110078	OPTIONAL	N/A
610143	110008	110024 419030	110012	510001 410444	110178	OPTIONAL	OPTIONAL
610144	110071	110024 419030	110012	510001 410444	110178	OPTIONAL	OPTIONAL
610145	110102	110024 419030	110012	510001 410444	110178	OPTIONAL	OPTIONAL
610146	110162	N/A	N/A	510041 410454	110208	N/A	N/A
610165	110022 110372	419007	110140 510241	510041 110022 110372	110009	N/A	N/A
610183	110102	110024 419030	110412 510371	510041 410381	110178	OPTIONAL	N/A
610184	110071	110024 419030	110412 510371	510041 410381	110178	OPTIONAL	N/A
610185	110008	110024 419030	110412 510371	510041 410381	110178	OPTIONAL	N/A
610187	110008	110024 419030	110140 510241	510041 410381	110178	OPTIONAL	N/A
610188	110071	110024 419030	110140 510241	510041 410381	110178	OPTIONAL	OPTIONAL
610189	110102	110024 419030	110140 510241	510041 410381	110178	OPTIONAL	OPTIONAL
610190	110008	110024 419030	110350 510331	510041 410381	110178	OPTIONAL	OPTIONAL
610191	110071	110024 419030	110350 510331	510041 410381	110178	OPTIONAL	OPTIONAL
610192	110102	110024 419030	110350 510331	510041 410381	110178	OPTIONAL	OPTIONAL

All rolling door components are 12' lengths and do not include fabrication.

# Rolling Doors

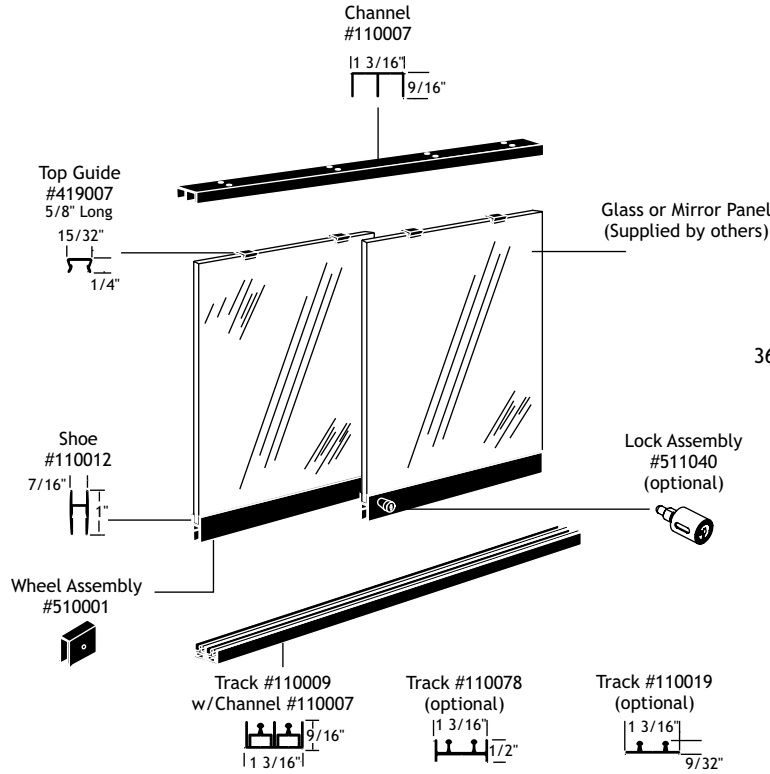

If a door height greater than 36" is needed, vertical moldings are required.

**Model #610005\***  
Standard assembly with removable track designed for easy cleaning

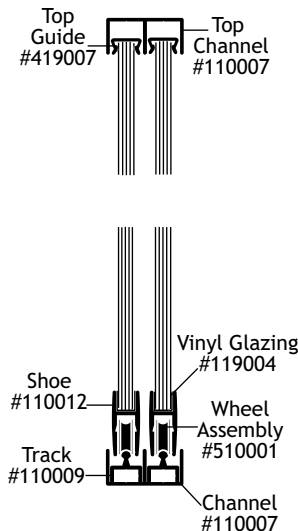

**Model #610007**  
Economy assembly using one piece double track

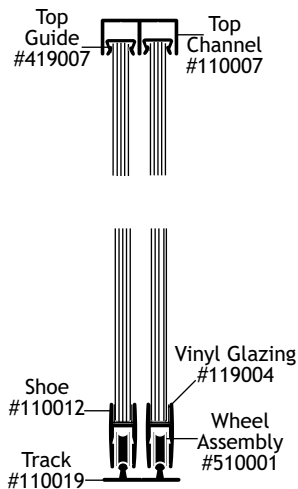

**Model #610099**  
Standard rolling door assembly

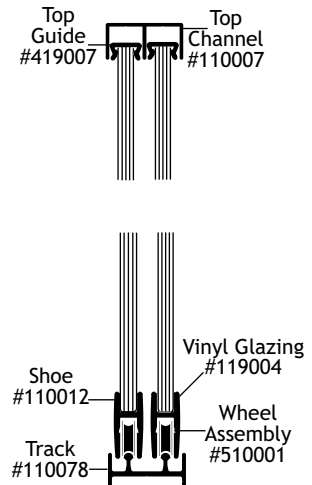

**Notes:** \* Model #610005 has several jamb options that would affect glass size. Please contact Stylmark Customer Service for assistance.

# Rolling Doors

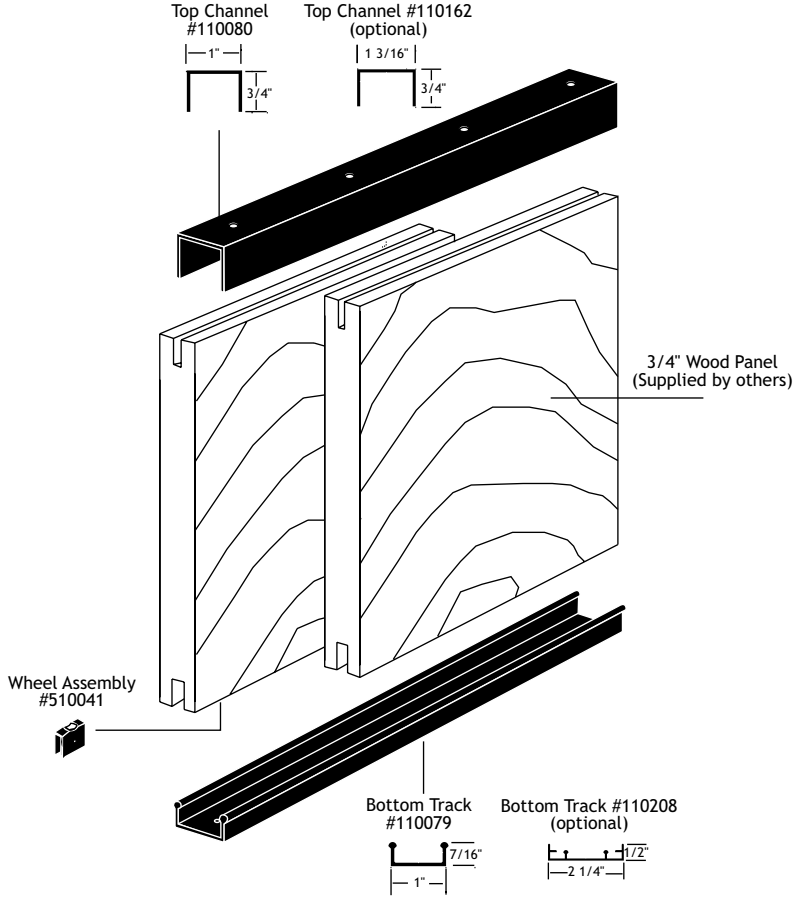

**Model #610060**  
 Double track for use  
 when security is not required

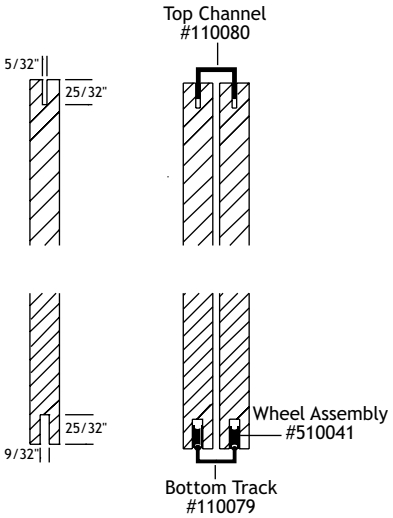

**Model #610146**  
 Double track for use  
 when security is required

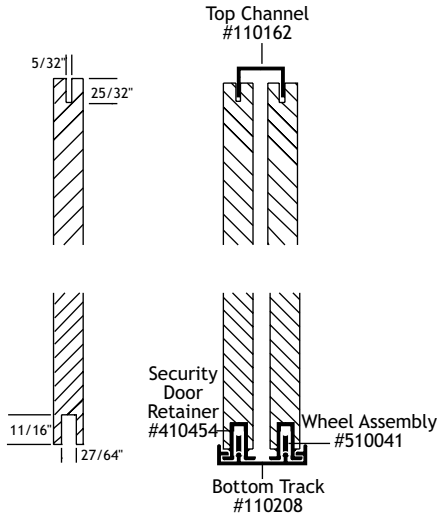

# Rolling Doors

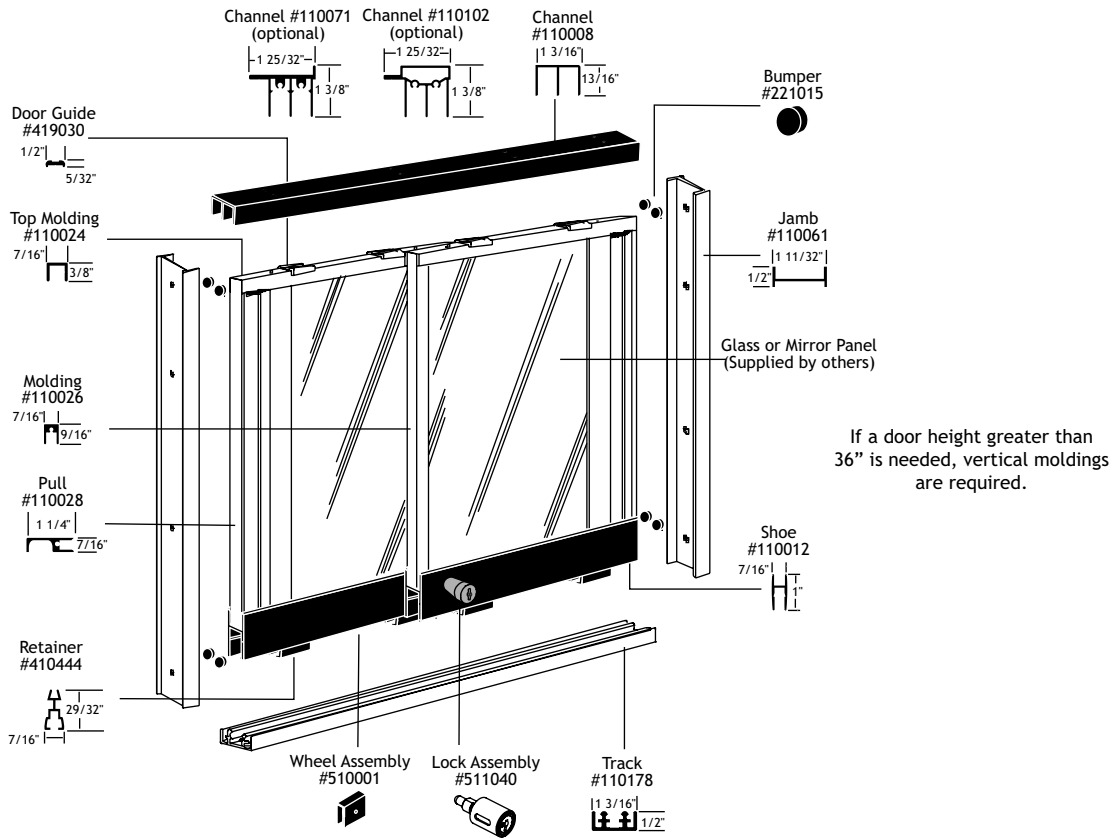

These security rolling door assemblies are for 1/4" panels up to 50 pounds.

### Model #610143

Features the 110008 header and 110012 shoe. Optional door verticals and jamba are available.

### Model #610144

Features the 110071 top header (back frame) and 110012 shoe.

### Model #610145

Features the 110102 top header (back frame) and 110012 shoe.

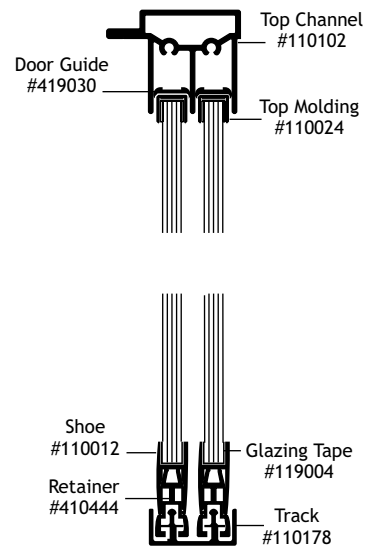
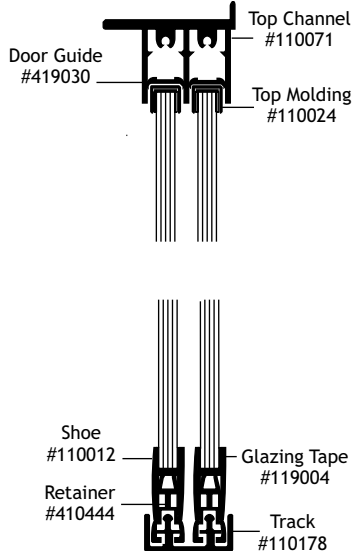
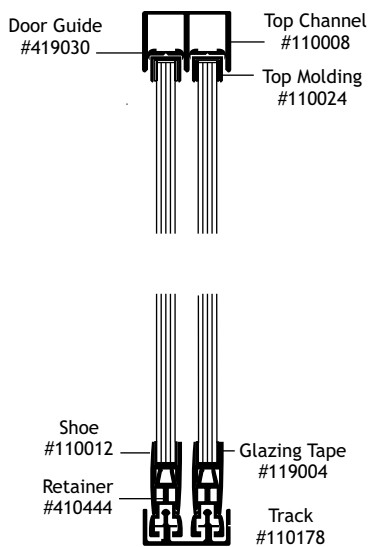

# Rolling Doors

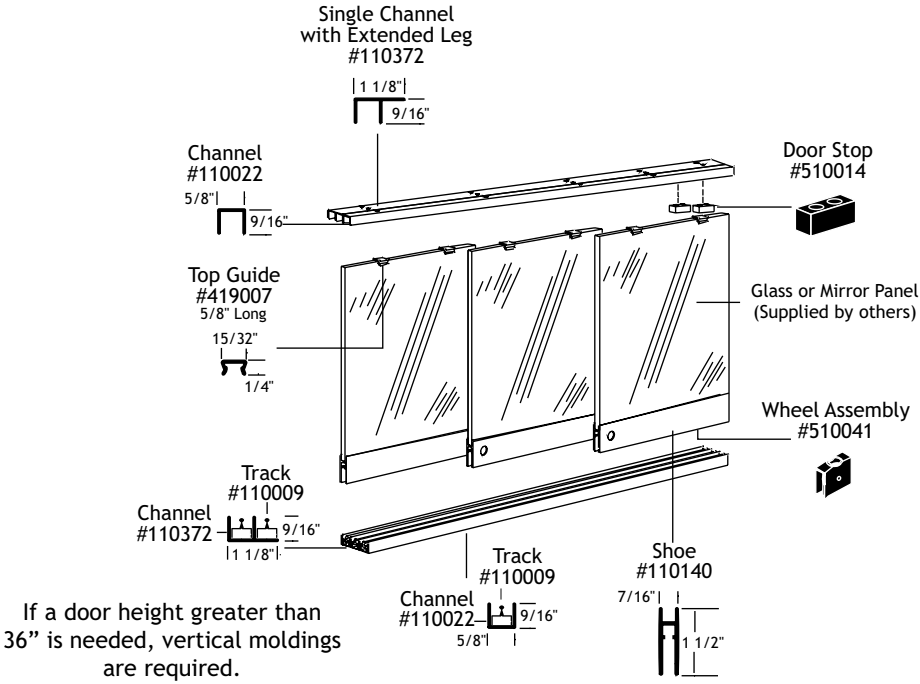

## Model #610165

Multiple tracks allow maximum usage of opening by stacking the doors for open access.

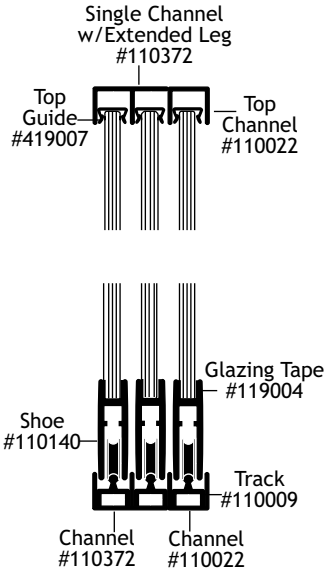

Notes: • Jambs and door verticals are available with fabricated assemblies.

# Rolling Doors

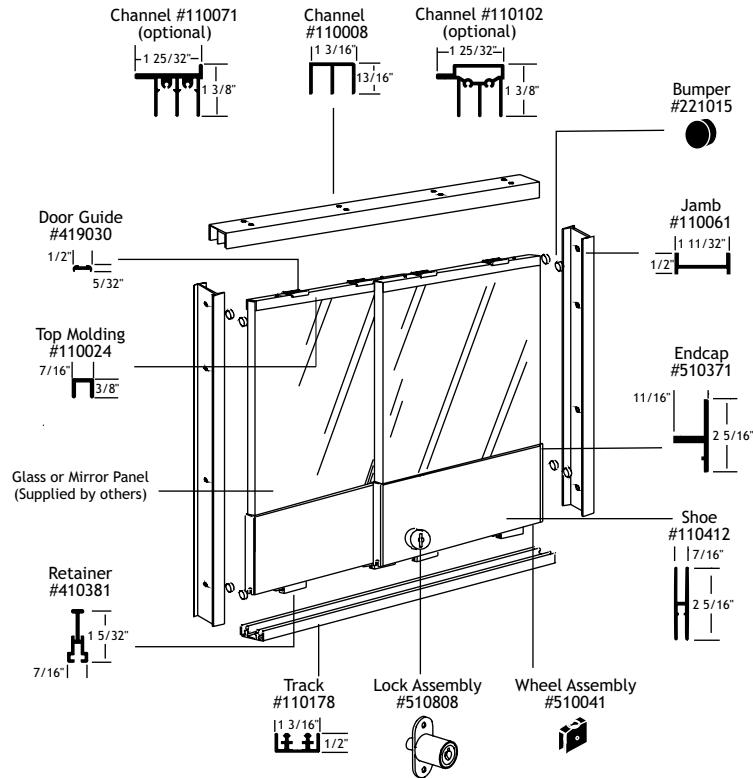

## Model #610183

Features the 110412 shoe with 110102 top header (back frame).

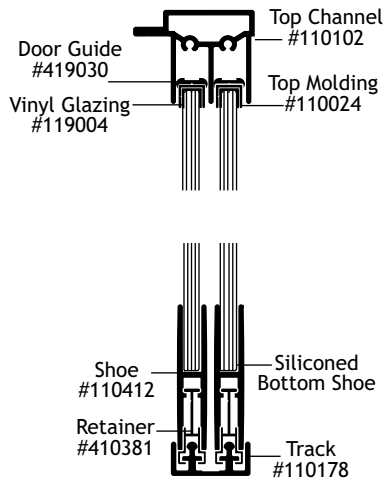

## Model #610184

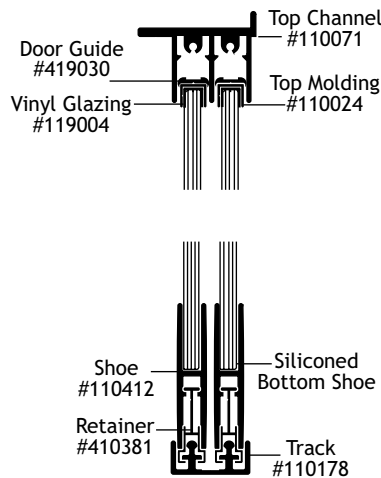

## Model #610185

Features the 110412 shoe with 110008 top header (back frame).

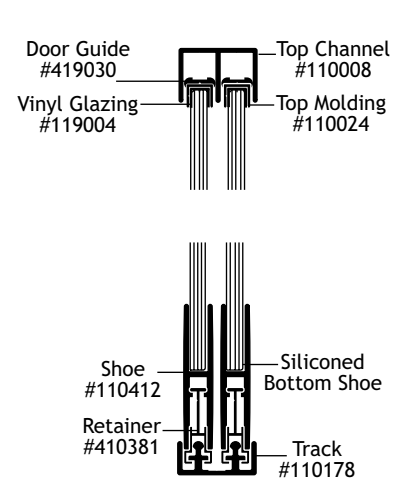

# Rolling Doors

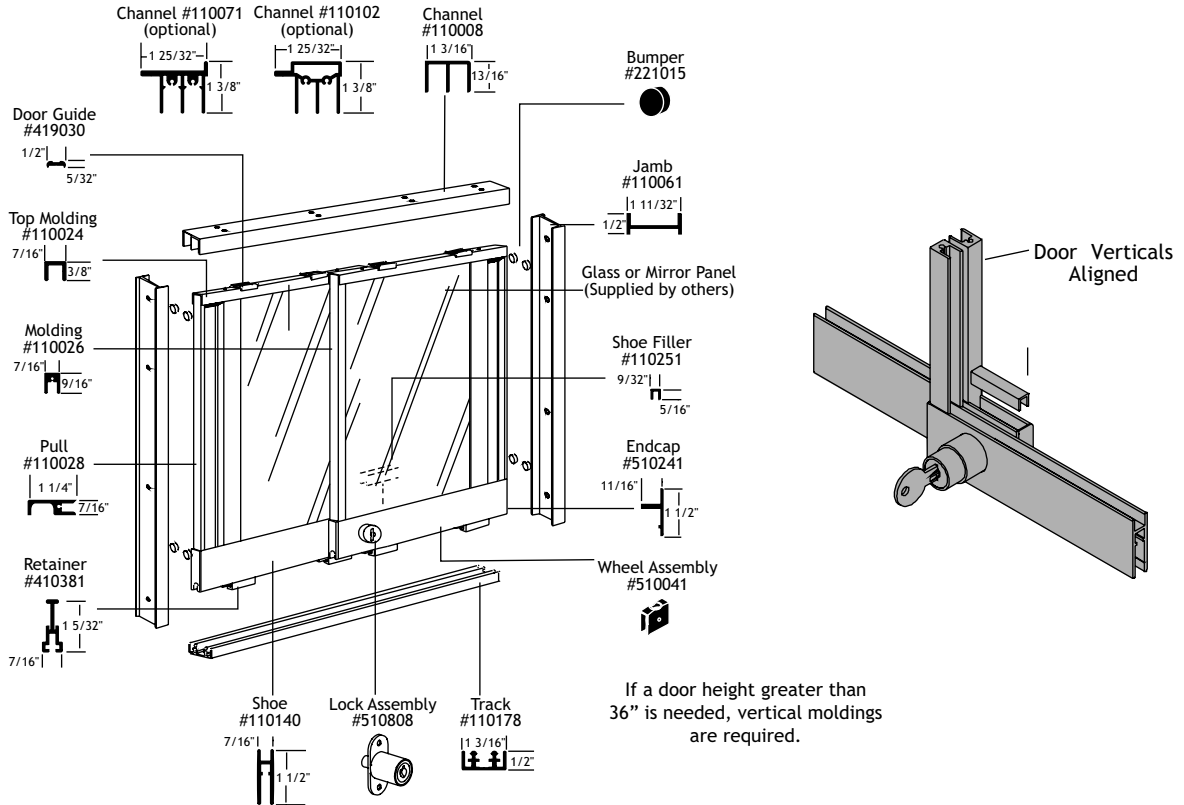

Security heavy duty rolling doors for 1/4" panels up to 80 pounds. Door verticals are standard, but you may order without. Assembly numbers 610187, 610188, and 610189 require overlapping doors to allow for alignment of door verticals. In this case, a shoe filler is used in the rear shoe. This overlap also enables glass for both front and rear doors to remain the same size (shown in picture inset).

## Model #610187

Features the 110008 top header and 110140 shoe.

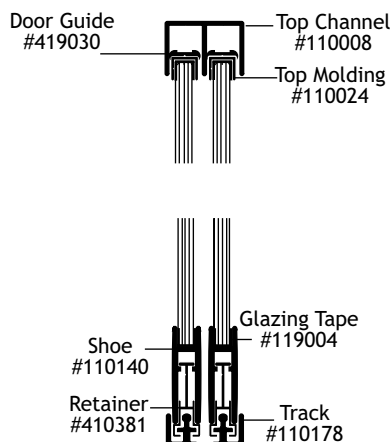

## Model #610188

Features the 110071 top header and 110140 shoe.

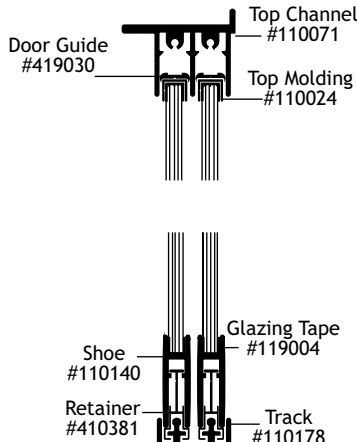

## Model #610189

Features the 110102 top header and 110140 shoe.

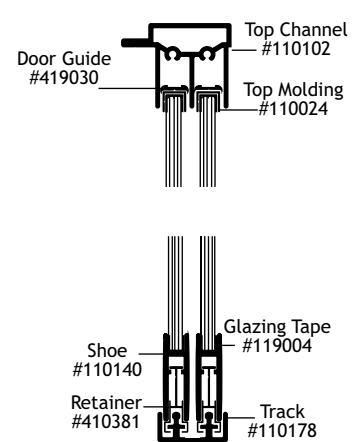

# Rolling Doors

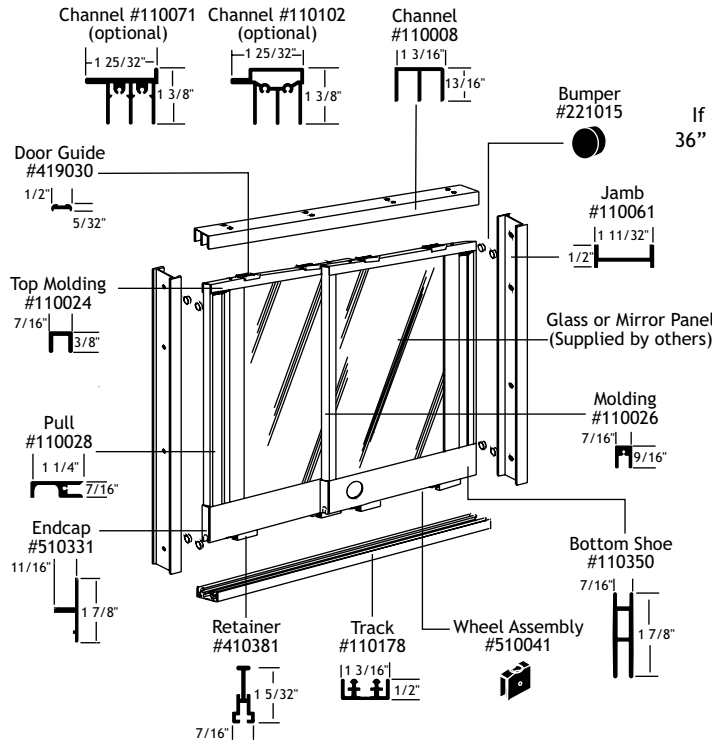

If a door height greater than 36" is needed, vertical moldings are required.

Note: Door verticals do not align

These assemblies feature the 110350 shoe, which accommodates the 4S Bestlock (supplied by others). Used for 1/4" panels up to 80 pounds. Door verticals are standard, but you may order without.

**Model #610190**  
Features the 110008 top header.

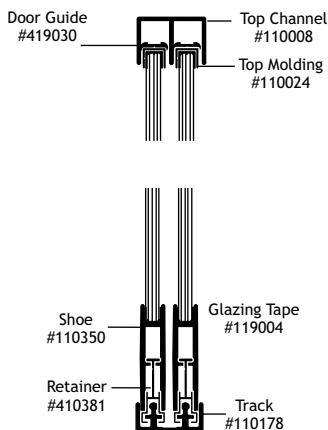

**Model #610191**  
Features the 110071 top header.

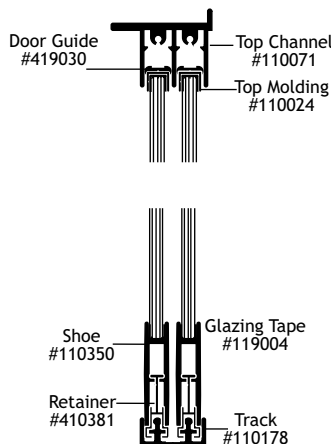

**Model #610192**  
Features the 110102 top header.

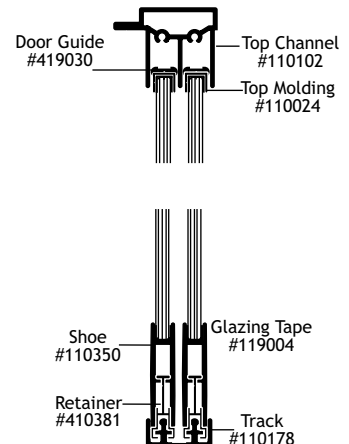

# Rolling Doors

## Door Panel and Glass Sizing Chart

HARDWARE ASSEMBLY NUMBER	WIDTH		HEIGHT
	WITH SIDE & CENTER VERTICALS DEDUCT FROM OPENING WIDTH AND DIVIDE BY 2	WITHOUT SIDE & CENTER VERTICALS ADD TO OPENING WIDTH AND DIVIDE BY 2	DEDUCT FROM OVERALL HEIGHT
*610005	1 7/8" ④	1" ③	1 15/32"
610007	1 7/8" ④	1" ③	1 7/32"
610060	-	1" ③	45/64"
610099	1 7/8" ④	1" ③	1 7/16"
610143	2 9/16" ①④	5/16" ①③	1 27/32"
610144	2 9/16" ①④	5/16" ①③	2 15/32"
610145	2 9/16" ①④	5/16" ①③	2 15/32"
610146	-	1"	13/16"
610165	-	4 (DIVIDE BY 3) ②	1 15/16"
610183	-	1 5/16" ①②	2 15/16"
610184	-	1 5/16" ①②	2 15/16"
610185	-	1 5/16" ①②	2 5/16"
610187	2 9/16" ①④	1 5/16" ①②	2 5/16"
610188	2 9/16" ①④	1 5/16" ①②	2 15/16"
610189	2 9/16" ①④	1 5/16" ①②	2 15/16"
610190	5/8" ①	-	2 11/16"
610191	5/8" ①	-	3 5/16"
610192	5/8" ①	-	3 5/16"

Note: \* Assembly 610005 has several jamb options that will affect glass size. Please contact Stylmark Customer Service for assistance.

- ① Jamb Included    ② 2" Door Overlap    ③ 1" Door Overlap  
 ④ 9/16" Door Overlap    ⑤ 2 1/2" Door Overlap

### Door Jamb and Mullions

Stylmark's door jambs serve as a filler when spaces are not completely plumb, and provide a vertical accent. Door mullions are typically used for header support and are recommended for spans of 63" or greater. They also serve as a divider and stop for multiple door applications.

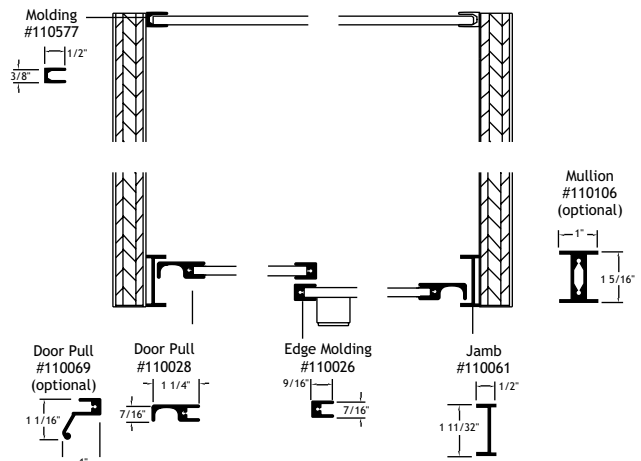

### Door Edge Molding and Pulls

When completely framed door panels are desired, door pulls and U-channel edge moldings are used, as shown.

# Rolling Doors

## Hardware and Accessories

Part #110007

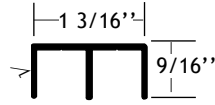

9/16"  
Double Channel

Part #110008

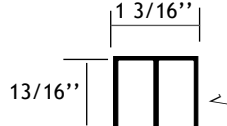

13/16"  
Double Channel

Part #110009

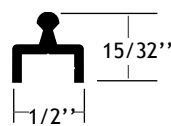

Drop In Track

Part #110012

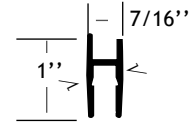

Shoe

Part #110014

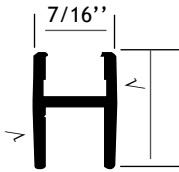

Glide Shoe

Part #110019

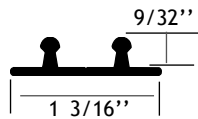

1 3/16"  
Double Track

Part #110021

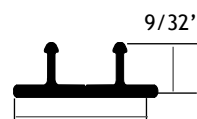

1 3/16"  
Glide Track

Part #110022

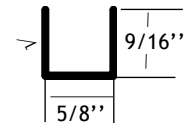

9/16" Single Channel

Part # 110023

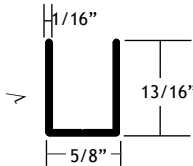

13/16" Single Channel

Part #110024

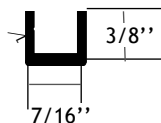

Edge Molding

Part #110026

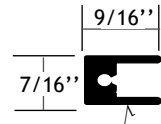

Edge Molding

Part #110027

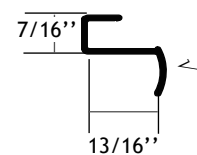

Door Pull

Part #110028

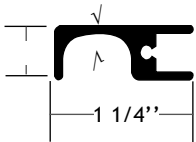

Flush Door Pull

Part #110029

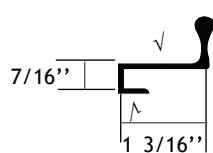

Door Pull

Part #110035

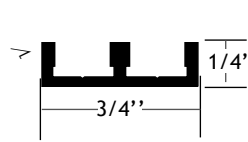

Slide Track

Part #110036

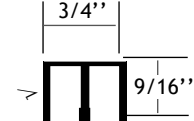

Slide Double Channel

Part #110061

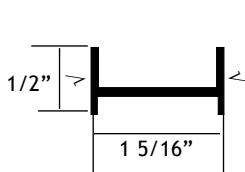

Jamb

Part #110063

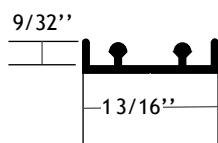

Double Channel Track

Part #110064

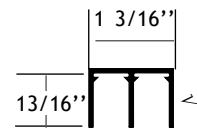

Double Channel

Part #110065

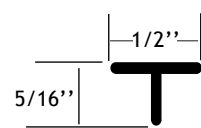

Anti-Jump Strip

**Notes:** • Stock length shoes do not include lock fabrication. Lock hole fabricated by customer.

√ = finished surface

# Rolling Doors

## Hardware and Accessories

Part #110066

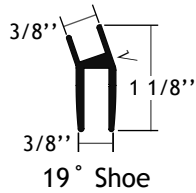

19° Shoe

Part #110067

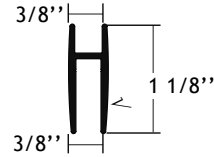

Part #110069

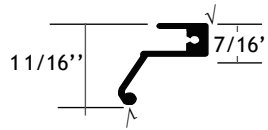

Door Pull

Part #110071

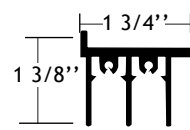

Part #110072

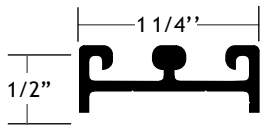

Slide Track

Part #110076

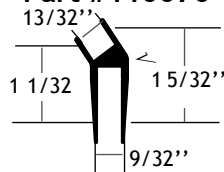

35° Deep Shoe

Part #110078

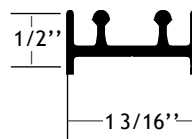

Channel Track

Part #110079

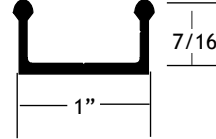

Wood Door Track

Part #110080

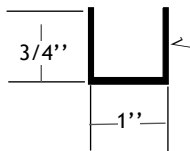

Top U Channel

Part #110102

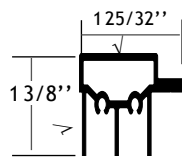

Top Rear Showcase Channel

Part #110140

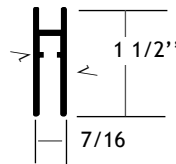

Heavy Duty Shoe

Part #110162

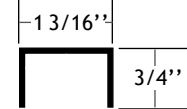

1 13/16" Top Channel

Part #110178

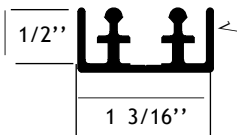

Security Track

Part #110208

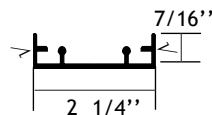

Part #110251

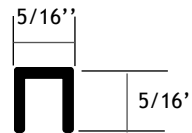

Shoe Filler

Part #110343

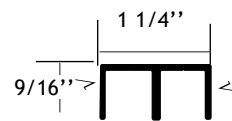

1 1/4" x 9/16" Double Channel

Part #110350

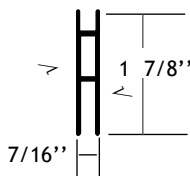

Heavy Duty Shoe

Part #110372

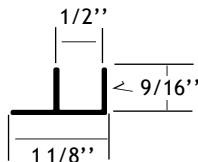

Single Channel with Extended Leg

Part #110412

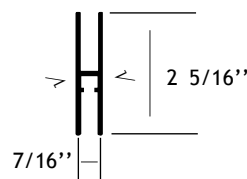

Deep Pocket Shoe

Part #110531\*

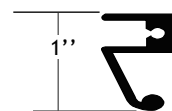

Door Pull

**Notes:**

- Stock length shoes do not include lock fabrication. Lock hole fabricated by customer.
- \*Part #110531 special order only.

√ = finished surface

# Rolling Doors

## Hardware and Accessories

Part #119004



1/4" Black Vinyl Glazing Tape (250 ft)

Part #221015

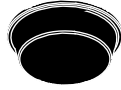

Clear Bumper

Part #410381

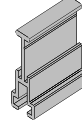

Part #410444

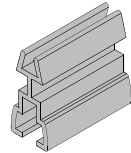

3/4" Security Door Retainer (use with 110012 shoe)

Part #410454

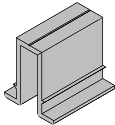

1 7/8" Security Door Retainer

Part #419007

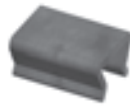

Top Guide

Part #419030



Vinyl Door Guide

Part #510001

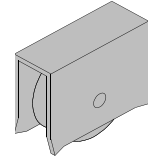

Wheel Assembly for 110012

Part #510006

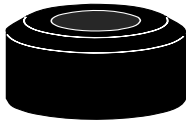

Door Bumper Assembly

Part #510014

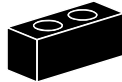

1/2" Heavy Duty Door Stop Assembly

Part #510015

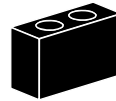

3/4" Heavy Duty Door Stop Assembly

Part #510041

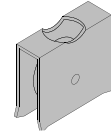

Heavy Duty Wheel Assembly

Part #510060

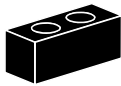

1/2" Heavy Duty Door Stop Assembly

Part #510241



Endcap Assembly for 110140

Part #510331



Part #510371

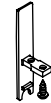

Endcap Assembly for 110412

Part #511040



Chrome Plunger Lock Assembly

Part #510808

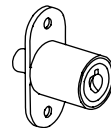

Chrome K-41 Plunger Lock Assembly

**Notes:** • Stock length shoes do not include lock fabrication. Lock hole fabricated by customer.

√ = finished surface