



Data Sheet

Café Series Food Display Partition Systems

Café Series – Glass Clamp



General Description: The Café Series from Stylmark consists of a variety of components used to create Food Display Partition Systems. The Glass Clamp system uses brackets to secure the glass to the post and provides a clean, modern aesthetic. A more traditional look is achieved with the Glass Channel system that uses recessed channels and plastic glazing to secure the glass. Posts are sold in 12' stock lengths for size customization. Optional accessories include end caps, shelf brackets and base canopies.

Applications: Sneeze guards, booth partitions, salad bar/cafeteria posts and glass shields

Material: Anodized aluminum

Anodized Finish: See Stylmark color library

Post Options: Integrated with single or double groove
Open with vertical bracket

Note: Posts are sold in 12' stock lengths

Café Series – Glass Channel

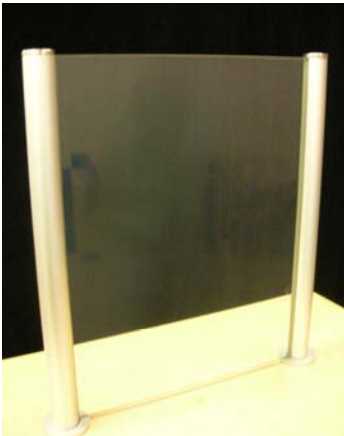

Glass: ¼" tempered glass (supplied by others)
6 mm tempered glass (supplied by others)

End caps: Screw in end cap for both systems

Mounting: Base and post mounting available

Shelf Option: Available for both Glass Clamp and Glass Channel systems

Multi Pane Option: Available in both systems

Swivel 220° Option: Available with Glass Clamp system only

In order to continually improve our products, Stylmark reserves the right to make changes to specifications or materials without prior notice.

Sheet# 971595
Revision B (11/11)

Layout Options

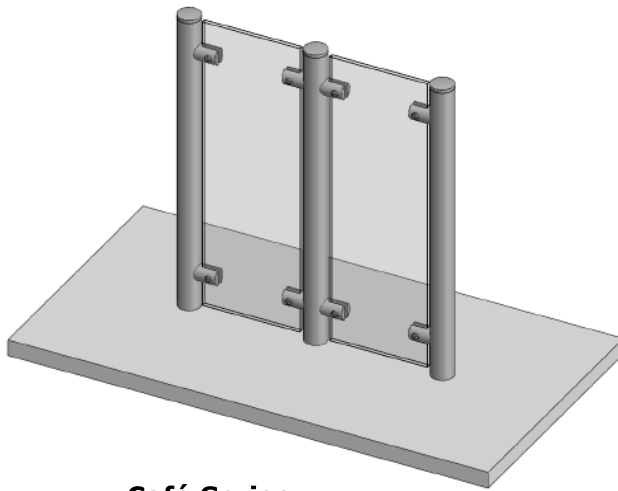

**Café Series
Multi Pane System**

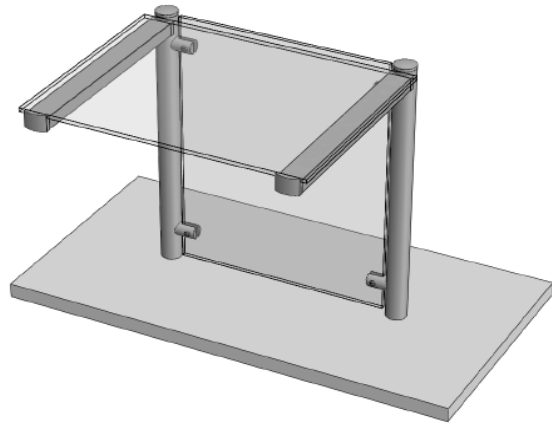

**Café Series
Shelf Option System**

Post Options

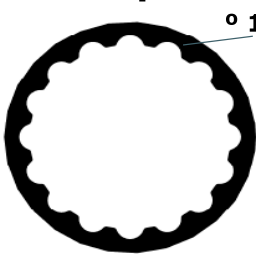

**#110853
Fluted Post
(glass clamp)**

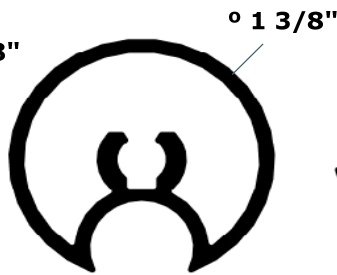

**#110854
Single Grove
Post
(glass channel)**

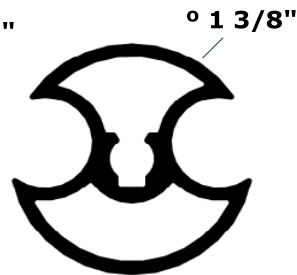

**#110855
Double Grove
Post
(glass channel)**

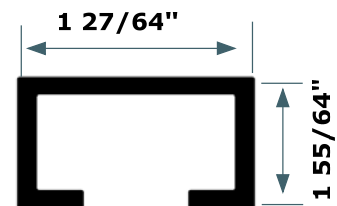

**#110856
U-Channel
(shelf option)**

Café Series Accessories

Glass Channel Accessories



**#511065
Endcap**



**#511070
Channel
Mounting Kit**



**#119045
Glazing**

Glass Clamp Accessories

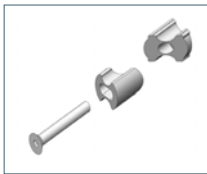

**#511069
Clamp
Mounting Kit**

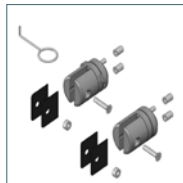

**#511078
Swivel Hinge
220° Assembly**



**#511079
Fixed Vertical
Bracket Kit**

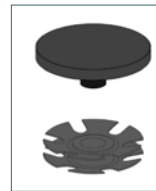

**#511085
Endcap with
Insert**

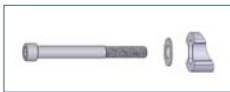

**#511121
Mounting Kit for
Glass Channel
Post, 20°**



**#511122
Mounting Kit for
Glass Clamp
Post, 20°**

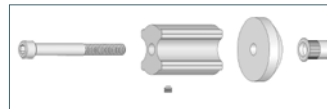

**#511124
Horizontal
Mounting Kit for
Glass Clamp Post**

Shelf Accessories

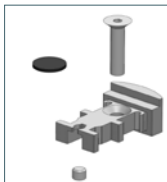

**#511066
Endcap
Bracket Kit**

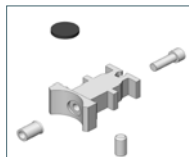

**#511067
Intermediate
Bracket Kit**

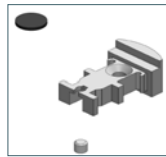

**# 511068
Endcap Bracket
Kit w/out
Fasteners**

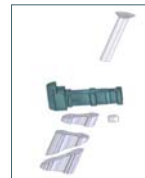

**# 511123
Shelf Intermediate
Bracket Kit, 20°**